



AFCO & BILLSTEIN RACE SHOCKS
Available by Special Order.....Contact Your HRP Sales Rep

SHOCKS & SPRINGS



We handle the entire line of Penske Shocks and Parts at very competitive pricing. Compare our Penske prices to other dealers.

For Penske parts and products not listed below call for part numbers and prices.

FREE DYNO SERVICE ON THE PURCHASE OF A CAR SET OF PENSKE SHOCKS

ADJUSTABLE DAMPERS



8100 Series Double Adjustable Aluminum Coil-over Damper

Available in lengths from 10" thru 24" in 1/2" increments for 2.25" or 2.50" springs. The compression adjuster is located on the remote reservoir, the rebound adjuster is located in the eyelet at the base of the shaft. Completely owner serviceable and revalvable
PSK-PS-8100

30 Day Guarantee on Double & Triple Adjustable Shocks

If you are not satisfied within 30 days you can return shocks for a full refund.

(Buyer is responsible for any damage to shocks)

8760 Series The Ultimate Triple Adjustable Damper

Available from 10" thru 24" in 1/2" increments for 2.00", 2.25" or 2.50" springs. Low speed and high speed compression adjustment located on the remote reservoir, the rebound adjuster is located at the base of the shaft. Completely owner serviceable, revalvable
PSK-PS-8760RM

INFORMATION NEEDED TO ORDER 8100, 8660, AND 8760 DAMPERS

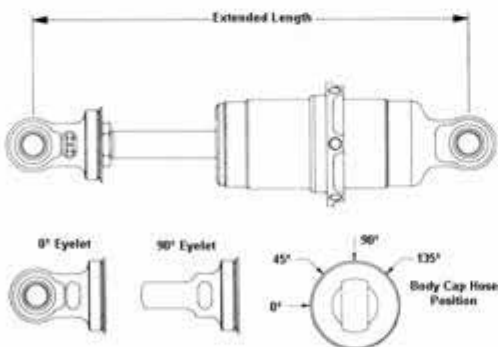

	FRONT	REAR
Shock series #		
Quantity		
Extended length		
Body cap hose position (0°, 45°, 90°, 135°)		
Fitting out of body cap (Straight, 45°, 90°)		
Hose length (4" thru 36" in 1" increments)		
Fitting on remote reservoir (Straight, 45°, 90°)		
Eyelet window position (0°, 90°)		
Piston bleed (.040", .020", no bleed)		
Piston dishing		
Spring I.D. to be used		
Compression valving		
Rebound valving		

SPECIALTY DAMPERS FOR OEM FITMENT



- Viper**
 Double Adjustable Front Damper PSK-PS-VIP81F
 Double Adjustable Rear Damper PSK-PS-VIP81R
 Triple Adjustable Front Damper PSK-PS-VIP87F
 Triple Adjustable Rear Damper PSK-PS-VIP87R

- Corvette C-5**
 Non-Adjustable Front Damper PSK-PS-75C5FNA
 Non-Adjustable Rear Damper PSK-PS-75C5RNA
 Double Adjustable Front Damper PSK-PS-81C5F
 Double Adjustable Rear Damper PSK-PS-81C5R



BimmerWorld Racing
#38 Seth Thomas
Speed GT-Touring



C/O SPRING SPACERS

- GEN-GC1032 2.25" ID x 1" Tall
- GEN-GC1033 2.25" ID x 2" Tall
- GEN-GC1030 2.50" ID x 1" Tall
- GEN-GC1031 2.50" ID x 2" Tall



BUMP RUBBERS

- PSK-BR-32 32 gram
- PSK-BR-38 38 gram



SPRING RETAINERS

- PSK-SR-81225 2.25", 8100/8400
- PSK-SR-81250 2.50", 8100/8400
- PSK-SR-87225 2.25", 8600/8700



SPRING PERCH NUTS

- PSK-RH-76225 2.25", 8760
- PSK-RH-81225 2.25", 8100/8400
- PSK-RH-81250 2.50", 8100/8400
- PSK-RH-87225 2.25", 8600/8700



REDUCER BUSHINGS

- 6061 T6 Aluminum
- Reduces shock from 1/2" to 3/8"
- 4 Required Per Shock
- GEN-GA1180



SHOCK SERVICE TOOLS

- PSK-TL-SHP Shaft End Plug
- PSK-TL-BDCL Body Clamp (aluminum body)
- PSK-TL-ALRNG Overflow Ring (aluminum body)



Shaft Bearing Wrenches

- PSK-TL-81W 8100 Series
- PSK-TL-76W 8760 Series
- LA22587 Double Ended, All Series



SHOCK WORKSTATION

- Holds body and shaft at the same time
- Clamp in vice or mount on bench with base
- JOES19200 Shock Workstation
- JOES19250 Workstation Base



REMOTE CANISTER CHASSIS MOUNT

- Universal, light gauge steel, weld or bolt to frame tube, use large tyrap or hose clamps to retain canister
- HR1045



COILOVER TOOLS

- 2.50" or 2.25" Spring Perches
- Steel Tool is Nickel Plated with Rubber Grip
- GEN-GT1040 Laser Cut Steel
- LA22589 Billet Aluminum



GENESIS SHOCK INFLATOR

- High PSI Inflation Unit
- With Pressure Gauge
- GEN-GT1020

LONGACRE SHOCK INFLATORS

- Special Chuck Prevents Pressure Loss
- Extra Long Hose
- Gauge Mounted at Convenient Angle
- Includes Foam Lined Case

- LA50470 0 to 160 PSI
- LA50471 0 to 3000 PSI
- LA50472 0 to 1000 PSI



CANISTER MOUNT

- Lightweight Billet Aluminum
- LA22764 1 3/4" Tube
- LA22765 1 1/2" Tube



TECHNICAL MANUAL

- Covers Adjustable Shocks
- PSK-MN-ADJSHOCKS



PENSKE SHOCK OIL

- Shock Oil (1 quart), 5 weight
- PSK-AC-OIL50Q

RED LINE LikeWater SUSPENSION FLUID

- Changes Very Little with Temperature
- Excellent Foaming Resistance
- RED-91102 16 oz



CANISTER MOUNT

- Lightweight Billet Aluminum
- LA22764 1 3/4" Tube
- LA22765 1 1/2" Tube

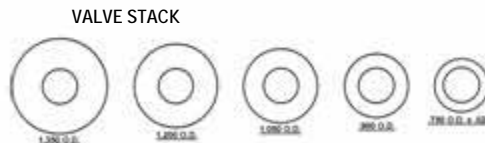
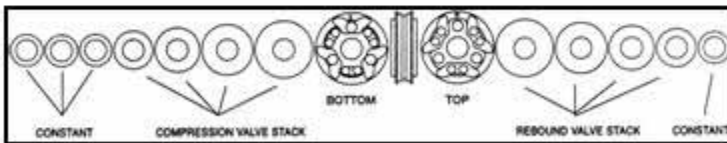

VALVE STACK PACKS...\$6.45 Each



AA	.004	.004	.004	.004	CONSTANT
AA+	.004	.004	.006	.006	CONSTANT
A	.006	.006	.006	.006	CONSTANT
A+	.006	.006	.008	.008	CONSTANT
B	.008	.008	.008	.008	CONSTANT
B+	.008	.008	.010	.010	CONSTANT

C	.010	.010	.010	.010	CONSTANT
C+	.010	.010	.012	.012	CONSTANT
D	.012	.012	.012	.012	CONSTANT
D+	.012	.012	.015	.015	CONSTANT
E	.015	.015	.015	.015	CONSTANT
E+	.015	.015	.020	.020	CONSTANT
F	.020	.020	.020	.020	CONSTANT



DYNO SERVICE
With Purchase of Car Set



**USED BY BMW & PORSCHE
FACTORY TEAMS**



FREE 2 Day Shipping from Holland at NO CHARGE

MOTON ADVANTAGES:

- Large Range of Adjustment - No need to change valving
- Superior Low Speed Control
- No Need for Shock Dyno - No shims
- Swivel Remote Canister Fittings - Mount in any position
- Maximum Fluid Displacement - Responds to small amounts of travel for today's low travel suspensions
- Adjustable Gas Pressure - Add from 50 to 170 Lbs. of spring rate to allow for softer suspension spring rates

SHOCKS & SPRINGS

MOTON RACING SHOCKS (4 WAY ADJUSTMENT FOR ALL SHOCKS NOW AVAILABLE - CALL FOR PRICE)

- ALUMINUM 2 WAY ADJUSTABLE COIL-OVER** Includes All Spring Hardware (Excluding Springs)
- ALUMINUM 3 WAY ADJUSTABLE COIL-OVER** Includes All Spring Hardware (Excluding Springs)
- ALUMINUM 4 WAY ADJUSTABLE COIL-OVER** Includes All Spring Hardware (Excluding Springs)

COMPLETE SETS FOR OEM FITMENT 4 Shocks

APPLICATION	2 WAY	3 WAY
ACURA INTEGRA GSR		
ACURA INTEGRA TYPE R		
ACURA NSX		
ACURA RSX TYPE R		
ACURA TSX		
ALFA ROMEO 147		
ALFA ROMEO 155 STW		
AUDI A4 QUATTRO		
AUDI S4		
BMW E30		
BMW E36 incl. M3 (Non C/O Rear)		
BMW E36 incl. M3 (C/O Rear)		
BMW E36 DTCC		
BMW E36 (FISA 2000 93)		
BMW E36 (FISA 2000 95)		
BMW E36 (FISA 2000 97)		
BMW E36 M3		
BMW E36 M3 (Gp A)		
BMW E46 330 CI (Steel Strut)		
BMW E46 330 CI (Alum. Strut)		
BMW E46 DTCC		
BMW E46 ETCC		
BMW E46 incl. M3 (Non C/O Rear)		
BMW E46 incl. M3 (C/O Rear)		
BMW Z3		
CAMARO		
CORVETTE C4		
CORVETTE C5		
CORVETTE C5-R		
DODGE NEON SRT-4		
DODGE VIPER GTS		
DODGE VIPER GTS-R		
DODGE VIPER RT-10		

COMPLETE SETS FOR OEM FITMENT Cont.

APPLICATION	2 WAY	3 WAY
DODGE VIPER SRT-10		
DODGE VIPER COMP. COUPE		
FERRARI 308 / 328		
FERRARI 333 SP		
FERRARI 348		
FERRARI 355		
FERRARI 360 STRADALE		
FERRARI 360 GT		
FERRARI 512 BBLM		
FERRARI 550		
FERRARI 575		
FERRARI F40		
FERRARI F50		
FORD FALCON		
FORD FOCUS		
FORD MONDEO		
FORD MUSTANG		
HONDA ACCORD TYPE R		
HONDA CIVIC Si		
HONDA CIVIC TYPE R '03		
HONDA PRELUDE		
HONDA S2000		
HYUNDAI TRIBURON		
LAMBORGHINI DIABLO		
LEXUS IS 300		
LOTUS ELISE Mk1 / Mk2		
LOTUS ELISE Mk3		
LOTUS ESPRIT TURBO		
LOTUS GTP		
MARCOS MANTIS		
MARCOS LM600		
MASERATI GT 3200		
MAZDA 6 2004		

COMPLETE SETS FOR OEM FITMENT Cont.

APPLICATION	2 WAY	3 WAY
MAZDA PROTEGE		
MAZDA RX7 (NEW STYLE)		
MAZDA RX7 (1ST GEN)		
MINI COOPER / COOPER S		
MITSUBISHI LANCER EVO 7 / 8		
NISSAN 240 SX		
NISSAN 350 Z		
NISSAN SENTRA '04		
PAGANI ZONDA		
PANOZ ESPERANTE		
PORSCHE 911 (EARLY)		
PORSCHE 928		
PORSCHE 935		
PORSCHE 944		
PORSCHE 944 TURBO / 968		
PORSCHE 962		
PORSCHE 964 RS AM / TURBO		
PORSCHE GT1		
PORSCHE 993 GT2		
PORSCHE 993 RS / RSR		
PORSCHE 993 TURBO		
PORSCHE 996 CUP		
PORSCHE 996 GT2 TWIN TURBO		
PORSCHE 996 GT-3 RSR		
PORSCHE 996 GT3-R / RS		
PORSCHE BOXSTER		
RENAULT CLIO		
RENAULT CLIO (Mid Engine)		
RENAULT MEGANE		
SALEEN S7R		
TOYOTA CELICA		
TOYOTA SUPRA		
ULTIMA GTR		

ACCESSORIES

- CANISTER Double Adjustable
- CANISTER Triple Adjustable
- QUICK DISCONNECT Includes 2 Swivel Banjo Hoses, Per Corner

- CAMBER PLATE BMW E46, Aluminum
- BMW SWAY BAR BRACKET E36 / E46, Adjustable
- PORSCHE SWAY BAR BRACKET 993 / 996, Adjustable

HYPERCO / IPC HYDRAULIC SPRING PERCH



GEN-GC1140

Hyperco calls it "Momentum Technology". It's two pieces of precision designed hardware that is placed on each end of a coil over spring. The Hydraulic Perch allows the spring to pivot during compression and extension. The result? A significant reduction in cross / axial side loads and the accompanying friction that is associated with these forces. In turn, this reduction of the side force and friction reduces load and wear on shock seals and allows more force and energy to be directed to the car's mechanical grip.

2.25"ID Spring For Moton, JRZ, Porsche OEM, Bilstein Shocks with M52x1.5 Thread-On Perch



HSP ADJUSTMENT WRENCH

Fits all thread-on HSP Spring Perches
GEN-GT1045



The new CLUB SPORT line is for the serious Club Racer and High Performance Street Racer. Bred from Moton's championship winning racing shocks, the new CLUB SPORT line has the same technology and precise adjustment range that has made Moton a leader in suspension technology.

The new CLUB SPORT line is a high-tech system, at an **affordable price**. CLUB SPORT is double adjustable with separate rebound and compression controls. Each has seven adjustment levels to help you dial in for every condition you encounter.

Dependable and easy to work with, this system will allow you to use a wide range of spring rates and eliminate the worry of having to revalve with each set of springs. They do not require constant maintenance to ensure they work properly—you can put them on and drive! They are made with the highest quality materials and workmanship available.

Now you too can have the winning edge with Moton's new CLUB SPORT line.



CLUB SPORT SHOCK SETS

4 Shocks with All Spring Hardware (Excluding Springs)

APPLICATION	2 WAY ADJ	APPLICATION	2 WAY ADJ
AUDI A4 QUATTRO (Rear QDs)		MINI COOPER / S (C/O Rear)	
AUDI S4 (Rear QDs)		MITSUBISHI LANCER Evo 7/8	
BMW E36 incl. M3 (non C/O Rear)		PORSCHE 944 (C/O Rear)	
BMW E36 incl. M3 (C/O Rear)		PORSCHE 944 TURBO (C/O Rear)	
BMW E46 incl. M3 (non C/O Rear)		PORSCHE 968 (C/O Rear)	
BMW E46 incl. M3 (C/O Rear)		PORSCHE 993	
BMW COMPACT (non C/O Rear)		PORSCHE 964	
DODGE VIPER SRT-10 (C/O All)		PORSCHE 996 Carrera 2/4/GT3/RS/GT2	
HONDA S2000		PORSCHE 996 GT3 Cup/GT3/RS	
FERRARI 355 (C/O All)		PORSCHE 996 RSR	
FERRARI 360 (C/O All)		PORSCHE 996 TURBO	
FERRARI 550 (C/O All)		PORSCHE BOXSTER / BOXSTER S	
		SUBARU IMPREZA WRX STI	

SHOCKS & SPRINGS

HYPERCOILS

THE ULTIMATE SUSPENSION COILS

LIFETIME GUARANTEE

2.5" I.D. COIL-OVER SPRINGS

4" Free Length Available - Call For Pricing



3" ID & Conventionals Available on Request

7" Free Length	8" Free Length	10" Free Length	12" Free Length	14" Free Length
HYP7B0175 175 LB	HYP8B0200 200 LB	HYP10B0095 95 LB	HYP12B0085 85 LB	HYP14B0100 .. 100 LB
HYP7B0200 200 LB	HYP8B0225 225 LB	HYP10B0110 .. 110 LB	HYP12B0095 95 LB	HYP14B0125 .. 125 LB
HYP7B0350 350 LB	HYP8B0250 250 LB	HYP10B0125 .. 125 LB	HYP12B0110 .. 110 LB	HYP14B0150 .. 150 LB
HYP7B0400 400 LB	HYP8B0275 275 LB	HYP10B0150 .. 150 LB	HYP12B0125 .. 125 LB	HYP14B0160 .. 160 LB
HYP7B0450 450 LB	HYP8B0300 300 LB	HYP10B0175 .. 175 LB	HYP12B0150 .. 150 LB	HYP14B0175 .. 175 LB
	HYP8B0325 325 LB	HYP10B0200 .. 200 LB	HYP12B0162 .. 162 LB	HYP14B0185 .. 185 LB
	HYP8B0350 350 LB	HYP10B0225 .. 225 LB	HYP12B0175 .. 175 LB	HYP14B0200 .. 200 LB
	HYP8B0375 375 LB	HYP10B0250 .. 250 LB	HYP12B0185 .. 185 LB	HYP14B0225 .. 225 LB
	HYP8B0400 400 LB	HYP10B0275 .. 275 LB	HYP12B0200 .. 200 LB	HYP14B0250 .. 250 LB
	HYP8B0425 425 LB	HYP10B0300 .. 300 LB	HYP12B0225 .. 225 LB	HYP14B0275 .. 275 LB
	HYP8B0450 450 LB	HYP10B0325 .. 325 LB	HYP12B0250 .. 250 LB	HYP14B0300 .. 300 LB
	HYP8B0475 475 LB	HYP10B0350 .. 350 LB	HYP12B0275 .. 275 LB	HYP14B0325 .. 325 LB
	HYP8B0500 500 LB	HYP10B0375 .. 375 LB	HYP12B0300 .. 300 LB	HYP14B0350 .. 350 LB
	HYP8B0525 525 LB	HYP10B0400 .. 400 LB	HYP12B0325 .. 325 LB	HYP14B0375 .. 375 LB
	HYP8B0550 550 LB	HYP10B0425 .. 425 LB	HYP12B0350 .. 350 LB	HYP14B0400 .. 400 LB
	HYP8B0575 575 LB	HYP10B0450 .. 450 LB	HYP12B0375 .. 375 LB	
	HYP8B0600 600 LB	HYP10B0475 .. 475 LB	HYP12B0400 .. 400 LB	
	HYP8B0650 650 LB	HYP10B0500 .. 500 LB	HYP12B0425 .. 425 LB	
	HYP8B0700 700 LB	HYP10B0525 .. 525 LB	HYP12B0450 .. 450 LB	
	HYP8B0750 750 LB	HYP10B0550 .. 550 LB	HYP12B0475 .. 475 LB	
	HYP8B0800 800 LB	HYP10B0575 .. 575 LB	HYP12B0500 .. 500 LB	
	HYP8B0850 850 LB	HYP10B0600 .. 600 LB	HYP12B0550 .. 550 LB	
	HYP8B0900 900 LB	HYP10B0625 .. 625 LB	HYP12B0600 .. 600 LB	
	HYP8B0950 950 LB	HYP10B0650 .. 650 LB	HYP12B0650 .. 650 LB	
	HYP8B1000 .. 1000 LB	HYP10B0675 .. 675 LB	HYP12B0700 .. 700 LB	
		HYP10B0700 .. 700 LB	HYP12B0750 .. 750 LB	
		HYP10B0725 .. 725 LB	HYP12B0800 .. 800 LB	
		HYP10B0750 .. 750 LB	HYP12B0850 .. 850 LB	
		HYP10B0800 .. 800 LB		
		HYP10B0850 .. 850 LB		
		HYP10B0900 .. 900 LB		



HELPER SPRINGS

Keeps Springs Indexed In Upper Retainer When Car is on Jackstands

- HYP-HS225 2.25" ID
- HYP-HS250 2.5" ID



HELPER SPRING GUIDES

Keeps Helper Spring Indexed with Main Spring

- GEN-GC1161 2.25" ID
- GEN-GC1160 2.50" ID



C/O SPRING SPACERS

Anodized T6 Aluminum

- GEN-GC1032 2.25" ID x 1" Tall
- GEN-GC1033 2.25" ID x 2" Tall
- GEN-GC1030 2.50" ID x 1" Tall
- GEN-GC1031 2.50" ID x 2" Tall



Moton Club Sport
Hypercoils



Larimer Racing
SOCA GT-1
2004 National Champion



LIFETIME GUARANTEE

2.25" I.D. COIL-OVER SPRINGS

4" Free Length

- HYP4A0300.... 300 LB
- HYP4A0350.... 350 LB
- HYP4A0400.... 400 LB
- HYP4A0450.... 450 LB
- HYP4A0500.... 500 LB
- HYP4A0550.... 550 LB
- HYP4A0600.... 600 LB
- HYP4A0650.... 650 LB
- HYP4A0700.... 700 LB
- HYP4A0750.... 750 LB
- HYP4A0800.... 800 LB
- HYP4A0850.... 850 LB
- HYP4A0900.... 900 LB
- HYP4A0950.... 950 LB
- HYP4A1000.... 1000 LB
- HYP4A1050.... 1050 LB
- HYP4A1100.... 1100 LB
- HYP4A1150.... 1150 LB
- HYP4A1200.... 1200 LB
- HYP4A1250.... 1250 LB
- HYP4A1300.... 1300 LB
- HYP4A1350.... 1350 LB
- HYP4A1400.... 1400 LB
- HYP4A1450.... 1450 LB
- HYP4A1500.... 1500 LB
- HYP4A1600.... 1600 LB
- HYP4A1700.... 1700 LB
- HYP4A1800.... 1800 LB
- HYP4A1900.... 1900 LB
- HYP4A2000.... 2000 LB
- HYP4A2100.... 2100 LB
- HYP4A2200.... 2200 LB
- HYP4A2300.... 2300 LB
- HYP4A2400.... 2400 LB
- HYP4A2500.... 2500 LB
- HYP4A2600.... 2600 LB
- HYP4A2700.... 2700 LB
- HYP4A2800.... 2800 LB
- HYP4A2900.... 2900 LB
- HYP4A3000.... 3000 LB
- HYP4A3800.... 3100 LB
- HYP4A3800.... 3200 LB
- HYP4A3800.... 3300 LB
- HYP4A3800.... 3400 LB

5" Free Length

- HYP5A0300.... 300 LB
- HYP5A0350.... 350 LB
- HYP5A0400.... 400 LB
- HYP5A0450.... 450 LB
- HYP5A0500.... 500 LB
- HYP5A0550.... 550 LB
- HYP5A0600.... 600 LB
- HYP5A0650.... 650 LB
- HYP5A0700.... 700 LB
- HYP5A0750.... 750 LB
- HYP5A0800.... 800 LB
- HYP5A0850.... 850 LB
- HYP5A0900.... 900 LB
- HYP5A0950.... 950 LB
- HYP5A1000.... 1000 LB
- HYP5A1050.... 1050 LB
- HYP5A1100.... 1100 LB
- HYP5A1150.... 1150 LB
- HYP5A1200.... 1200 LB
- HYP5A1250.... 1250 LB
- HYP5A1300.... 1300 LB
- HYP5A1350.... 1350 LB
- HYP5A1400.... 1400 LB
- HYP5A1450.... 1450 LB
- HYP5A1500.... 1500 LB
- HYP5A1550.... 1550 LB
- HYP5A1600.... 1600 LB
- HYP5A1650.... 1650 LB
- HYP5A1700.... 1700 LB
- HYP5A1750.... 1750 LB
- HYP5A1800.... 1800 LB
- HYP5A1850.... 1850 LB
- HYP5A1900.... 1900 LB
- HYP5A1950.... 1950 LB
- HYP5A2000.... 2000 LB
- HYP5A2100.... 2100 LB
- HYP5A2200.... 2200 LB
- HYP5A2300.... 2300 LB
- HYP5A2400.... 2400 LB
- HYP5A2500.... 2500 LB
- HYP5A2600.... 2600 LB
- HYP5A2700.... 2700 LB
- HYP5A2800.... 2800 LB
- HYP5A2900.... 2900 LB
- HYP5A3000.... 3000 LB
- HYP5A3800.... 3800 LB

6" Free Length

- HYP6A0200.... 200 LB
- HYP6A0225.... 225 LB
- HYP6A0250.... 250 LB
- HYP6A0275.... 275 LB
- HYP6A0300.... 300 LB
- HYP6A0325.... 325 LB
- HYP6A0350.... 350 LB
- HYP6A0375.... 375 LB
- HYP6A0400.... 400 LB
- HYP6A0425.... 425 LB
- HYP6A0450.... 450 LB
- HYP6A0475.... 475 LB
- HYP6A0500.... 500 LB
- HYP6A0550.... 550 LB
- HYP6A0600.... 600 LB
- HYP6A0650.... 650 LB
- HYP6A0700.... 700 LB
- HYP6A0750.... 750 LB
- HYP6A0800.... 800 LB
- HYP6A0850.... 850 LB
- HYP6A0900.... 900 LB
- HYP6A0950.... 950 LB
- HYP6A1000.... 1000 LB
- HYP6A1050.... 1050 LB
- HYP6A1100.... 1100 LB
- HYP6A1150.... 1150 LB
- HYP6A1200.... 1200 LB
- HYP6A1250.... 1250 LB
- HYP6A1300.... 1300 LB
- HYP6A1400.... 1400 LB
- HYP6A1500.... 1500 LB
- HYP6A1600.... 1600 LB
- HYP6A1700.... 1700 LB
- HYP6A1800.... 1800 LB
- HYP6A1900.... 1900 LB
- HYP6A2000.... 2000 LB
- HYP6A2200.... 2200 LB
- HYP6A2500.... 2500 LB

7" Free Length

- HYP7A0250.... 250 LB
- HYP7A0275.... 275 LB
- HYP7A0300.... 300 LB
- HYP7A0325.... 325 LB
- HYP7A0350.... 350 LB
- HYP7A0375.... 375 LB
- HYP7A0400.... 400 LB
- HYP7A0425.... 425 LB
- HYP7A0450.... 450 LB
- HYP7A0475.... 475 LB
- HYP7A0500.... 500 LB
- HYP7A0525.... 525 LB
- HYP7A0550.... 550 LB
- HYP7A0600.... 600 LB
- HYP7A0650.... 650 LB
- HYP7A0700.... 700 LB
- HYP7A0750.... 750 LB
- HYP7A0800.... 800 LB
- HYP7A0850.... 850 LB
- HYP7A0900.... 900 LB
- HYP7A0950.... 950 LB
- HYP7A1000.... 1000 LB
- HYP7A1050.... 1050 LB
- HYP7A1100.... 1100 LB
- HYP7A1200.... 1200 LB
- HYP7A1300.... 1300 LB
- HYP7A1400.... 1400 LB
- HYP7A1500.... 1500 LB
- HYP7A1600.... 1600 LB

8" Free Length

- HYP8A0150.... 150 LB
- HYP8A0175.... 175 LB
- HYP8A0200.... 200 LB
- HYP8A0225.... 225 LB
- HYP8A0250.... 250 LB
- HYP8A0275.... 275 LB
- HYP8A0300.... 300 LB
- HYP8A0325.... 325 LB
- HYP8A0350.... 350 LB
- HYP8A0375.... 375 LB
- HYP8A0400.... 400 LB
- HYP8A0425.... 425 LB
- HYP8A0450.... 450 LB
- HYP8A0475.... 475 LB
- HYP8A0500.... 500 LB
- HYP8A0525.... 525 LB
- HYP8A0550.... 550 LB
- HYP8A0575.... 575 LB
- HYP8A0600.... 600 LB
- HYP8A0650.... 650 LB
- HYP8A0700.... 700 LB
- HYP8A0750.... 750 LB
- HYP8A0800.... 800 LB
- HYP8A0900.... 900 LB
- HYP8A1000.... 1000 LB
- HYP8A1100.... 1100 LB
- HYP8A1200.... 1200 LB

9" Free Length

- HYP9A0150.... 150 LB
- HYP9A0175.... 175 LB
- HYP9A0200.... 200 LB
- HYP9A0225.... 225 LB
- HYP9A0250.... 250 LB
- HYP9A0275.... 275 LB
- HYP9A0300.... 300 LB
- HYP9A0325.... 325 LB
- HYP9A0350.... 350 LB
- HYP9A0375.... 375 LB
- HYP9A0400.... 400 LB
- HYP9A0425.... 425 LB
- HYP9A0450.... 450 LB
- HYP9A0475.... 475 LB
- HYP9A0500.... 500 LB
- HYP9A0550.... 550 LB
- HYP9A0600.... 600 LB
- HYP9A0750.... 750 LB

SHOCKS & SPRINGS

Springs and Accessories



SMALL DIAMETER COILOVER SPRINGS

- 2.0" I.D. SPRINGS Available in 4", 5" and 6" Free Lengths
- 1.875" I.D. SPRINGS Available in 10" and 12" Free Lengths
- 1.487" I.D. SPRINGS Available in 5" Free Length



COMPOSITE LEAF SPRINGS

*Lighter...*70% less weight than steel
*Stronger...*More durable & consistent than steel
*Faster...*Incredible side bite - Quicker off the corner

Chevrolet Composite Leaf Springs
Available in 5 Rates (150, 175, 200, 225, 275 lbs)
HYP-113XX Specify Rate

Chrysler Composite Leaf Springs
Available in 6 Rates (35, 50, 150, 175, 200, 225 lbs)
HYP-102XX Specify Rate



SPRING RUBBERS

Fine Tune Your Spring Rate
Used by All Nextel Cup Teams



- C/O Spring Rubbers**
- LA61005 Yellow 5 l
 - LA61010 Clear 10 lb
 - LA61015 Orange 15 lb
 - LA61040 Red 40 lb
 - LA61050 Blue 50 lb
 - LA61070 Black 70 lb

- 5"/5.5" Spring Rubbers**
Pro Series with Handles & Grips
- LA61140 Red STD Soft
 - LA61150 Blue STD Medium
 - LA61170 Black STD Hard
 - LA61240 Red PRO Soft
 - LA61250 Blue PRO Medium
 - LA61270 Black PRO Hard



HYPERCO / IPC HYDRAULIC SPRING PERCH

Hyperco calls it "Momentum Technology". It's two pieces of precision designed hardware that is placed on each end of a coil over spring. The Hydraulic Perch allows the spring to pivot during compression and extension. The result? A significant reduction in cross / axial side loads and the accompanying friction that is associated with these forces. In turn, this reduction of the side force and friction reduces load and wear on shock seals and allows more force and energy to be directed to the car's mechanical grip.

- HYP-HHPERCH-2.00 2"ID Spring Slide-On Perch
- HYP-HHPERCH-2.25 2.25"ID Spring Slide-On Perch
- HYP-HHPERCH-2.50 2.5"ID Spring Slide-On Perch
- HYP-HHBODPENSKE-2.25 2.25"ID Spring Penske 8760 Shock Thread-On Perch
- HYP-HHBODJHLINS-2.25 2.25"ID Spring Ohlins Shock Thread-On Perch
- GEN-GC1140 2.25"ID Spring Moton, JRZ, Porsche OEM, Bilstein Shocks M52x1.5 Thread-On Perch

HSP ADJUSTMENT WRENCH See page 58 GEN-GT1045